

CHAINS FOR SPECIAL APPLICATIONS – BRICK INDUSTRY

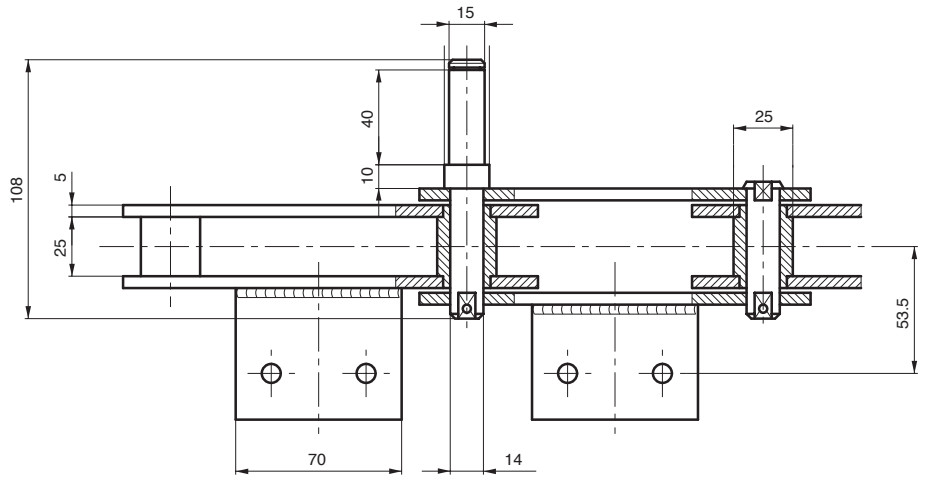

Chain P. 125x25x25 øB

 Breaking load: 100.000 N

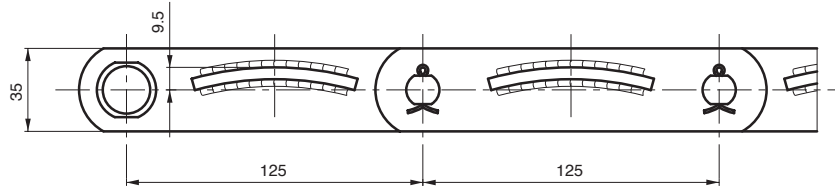
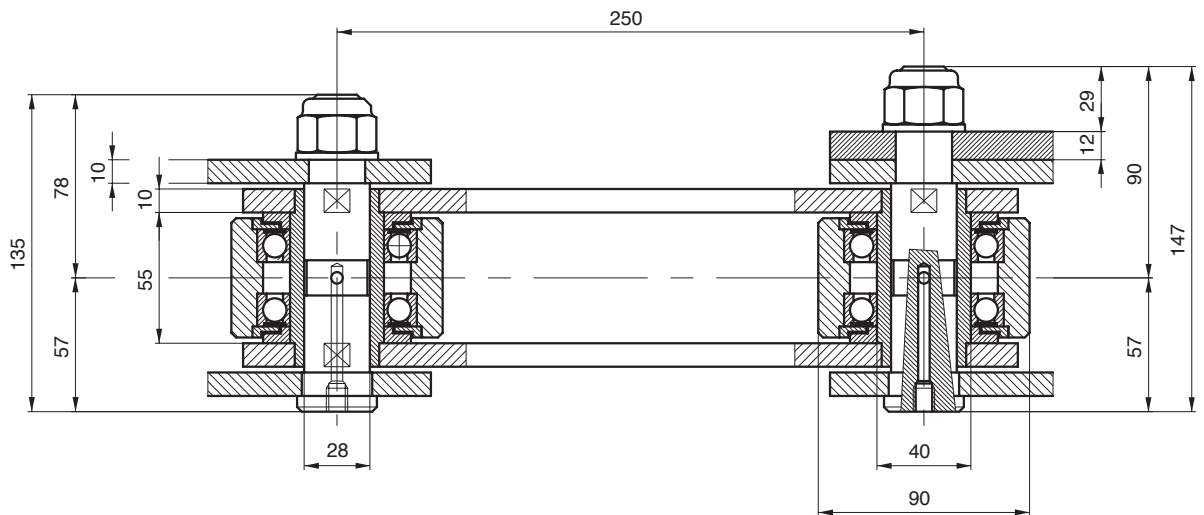

SHOVEL
EXCAVATORS

Chain P. 250x55x90 øR

 Breaking load: 500.000 N